

EnviroBasin™

Water Quality Inlet

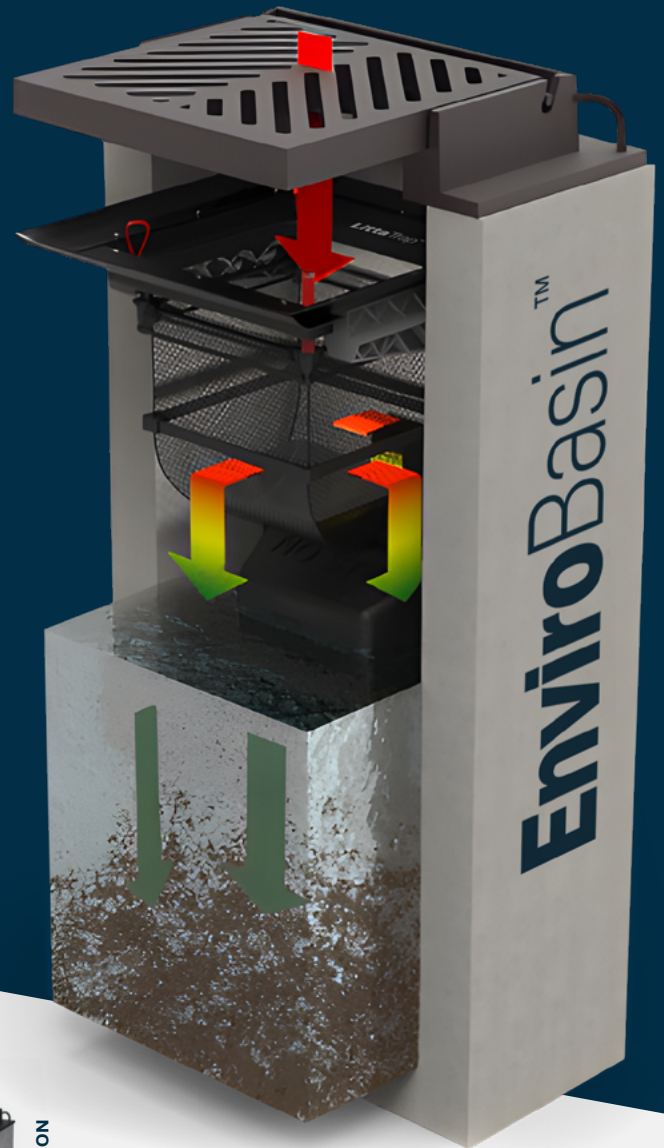

DITCH



COMBO



JUNCTION

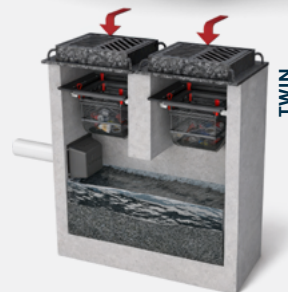

TWIN

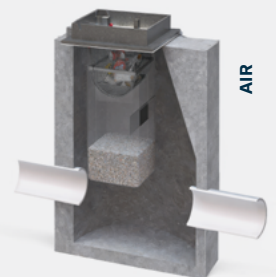

AIR

Six Configurations.
One Integrated ETV-verified System.

The EnviroBasin™

The EnviroBasin™ is an engineered water quality inlet offering two functions:

1. Conveyance of stormwater runoff from ground level into the reticulation system; and
2. Removal of pollutants and improvement of water quality.

The EnviroBasin™ consists of a modified LittaTrap™ catch basin insert installed into a pre-cast catch basin to dissipate energy, promote sedimentation and provide full capture of gross solids 5 mm in diameter and greater in stormwater runoff. This is done by the LittaTrap™ device in conjunction with an energy dissipator dish and submerged outlet baffle.

The system is easy and safe to maintain, with large storage capacity relative to its catchment area. Confined space entry is not required.

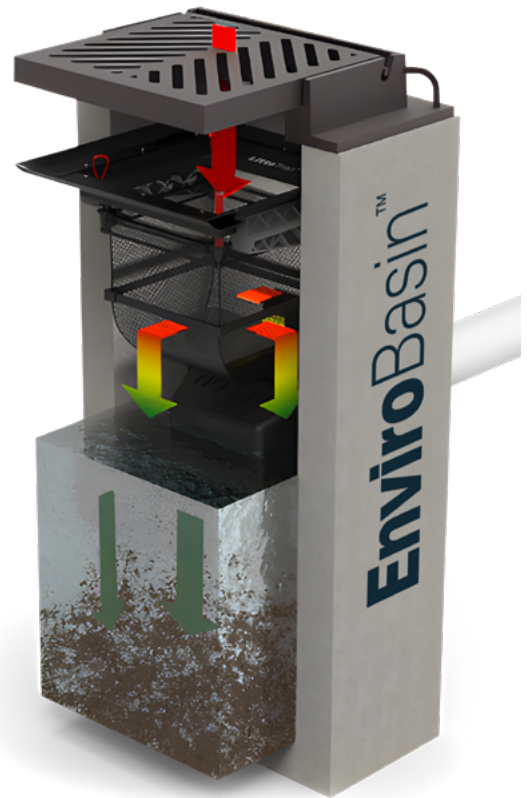

EnviroBasin™ Standard Grate Inlet



ISO 14034
ETV VERIFIED



Manufactured
in Canada.

The EnviroBasin™ eliminates the need for downstream oil and grit separators, as it treats the stormwater at the source before it enters the stormwater system.

FEATURES

- High flow, dry gross solid storage enhances nutrient removal.
- Hand maintenance of gross pollutant basket;
 - Reduces sump vector maintenance frequency.
 - No confined space entry required.
 - Large sediment sump storage volume.
- Enhanced energy dissipation and flow distribution provides:
 - →50% ETV PSD TSS Removal.
 - →80% (20–1000 micron) TSS Removal.
 - Reduced resuspension and contamination release.
- Lower carbon footprint when compared with downstream OGS solutions.

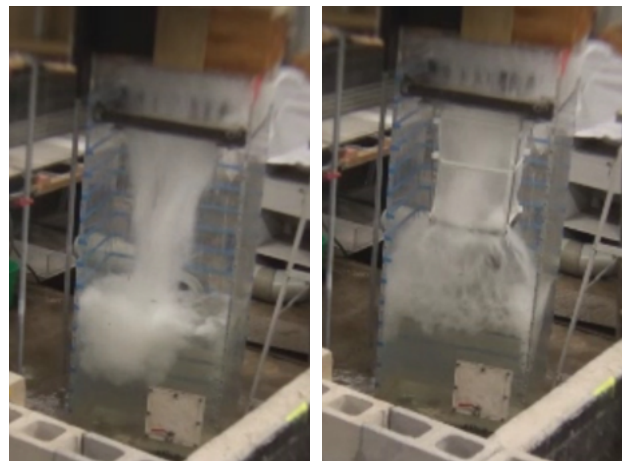

Turbulence in sumped stormwater inlet (left) and EnviroBasin™ (Right)

TREATABLE CATCHMENT AREA

Each jurisdiction supplies guidance around the hydraulic design, location, and capture capacity of stormwater inlets. Catchment area, gradient, cross fall, configuration, dimensions, and grate all affect the inlet capacity of a catch basin and therefore, the spacing.

The maximum catchment area of the EnviroBasin™ is typically governed by the ability of the peak capture flow of the device, i.e. the inflow for a 5 or 10-year design storm.

EnviroPod™ in conjunction with AECOM Canada have developed a performance estimating tool to determine the Total Suspended Solids (TSS) removal of the EnviroBasin™ for a given catchment. The performance estimating tool uses third party performance data obtained from Canadian Environmental Technology Verification Program (CETV) procedure for Laboratory Testing of Oil-Grit Separators ISO14034 testing and historical rainfall data to estimate flow, determine surface loading rate and estimate performance for a catchment area.



Field Trials

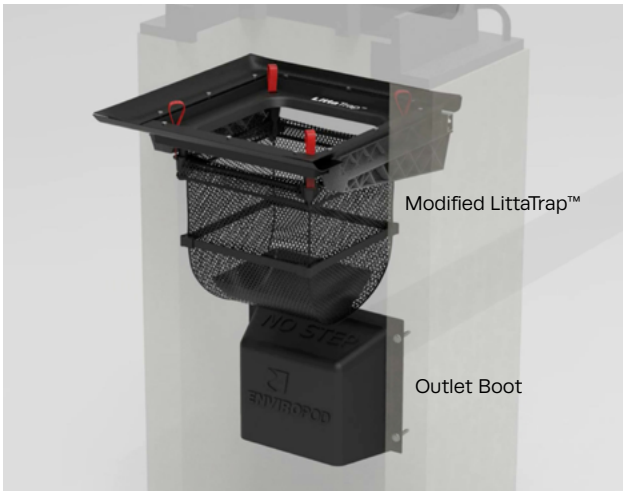

EnviroBasin™ Components

EnviroPod™ Construction Liner

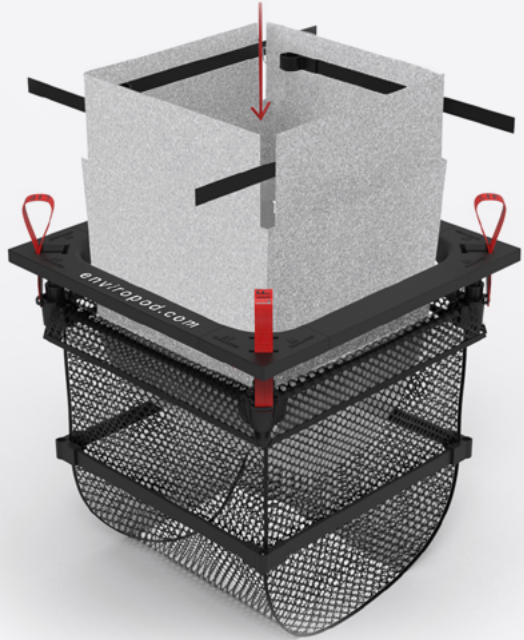

EnviroBasin™ installed with a EnviroPod™ Geotextile Constriction Liner protects the catch basin from construction to completion.

- **One product for two jobs**
Provides construction and post-construction trash control.
- **Easy maintenance.** The construction liner is supported by the LittaTrap™ basket allowing easy removal and replacement.
- **Hydraulically designed** not to cause flooding.
- **Cost savings.** Construction liners are a low cost addition to your site.
- **Readily available** online and through distributors.



- ✓ High hydraulic capacity
- ✓ Large sediment storage volume
- ✓ Structurally robust
- ✓ Easily maintained



- ✗ Blocks storm drain
- ✗ Can't be maintained
- ✗ Ineffective

MODEL AND SIZE SPECIFICATION

The EnviroBasin™ has six models. Table 1 below details the standard models available.

Model	Modified LittaTrap™ Size	Impervious area for 60% TSS* (m ²)	Gross Solid Storage (L)	Sediment Storage (m ³)
Standard	LT6060	950	43	0.32
London Combination	LT6060 with seal kit	1330	43	0.45
Twin	2 x LT6060	2300	86	0.78
Ditch	LT6060	950	43	0.32
Junction	LT6060	950	43	0.32
EnviroBasin Air	Catch basin manhole retrofit. Contact EnviroPod™ for more info.			

*Estimated using ETV PSD modeled in a specification based on 6 hour 25mm storm depth. Note this is a guide only and site specific design may be required.

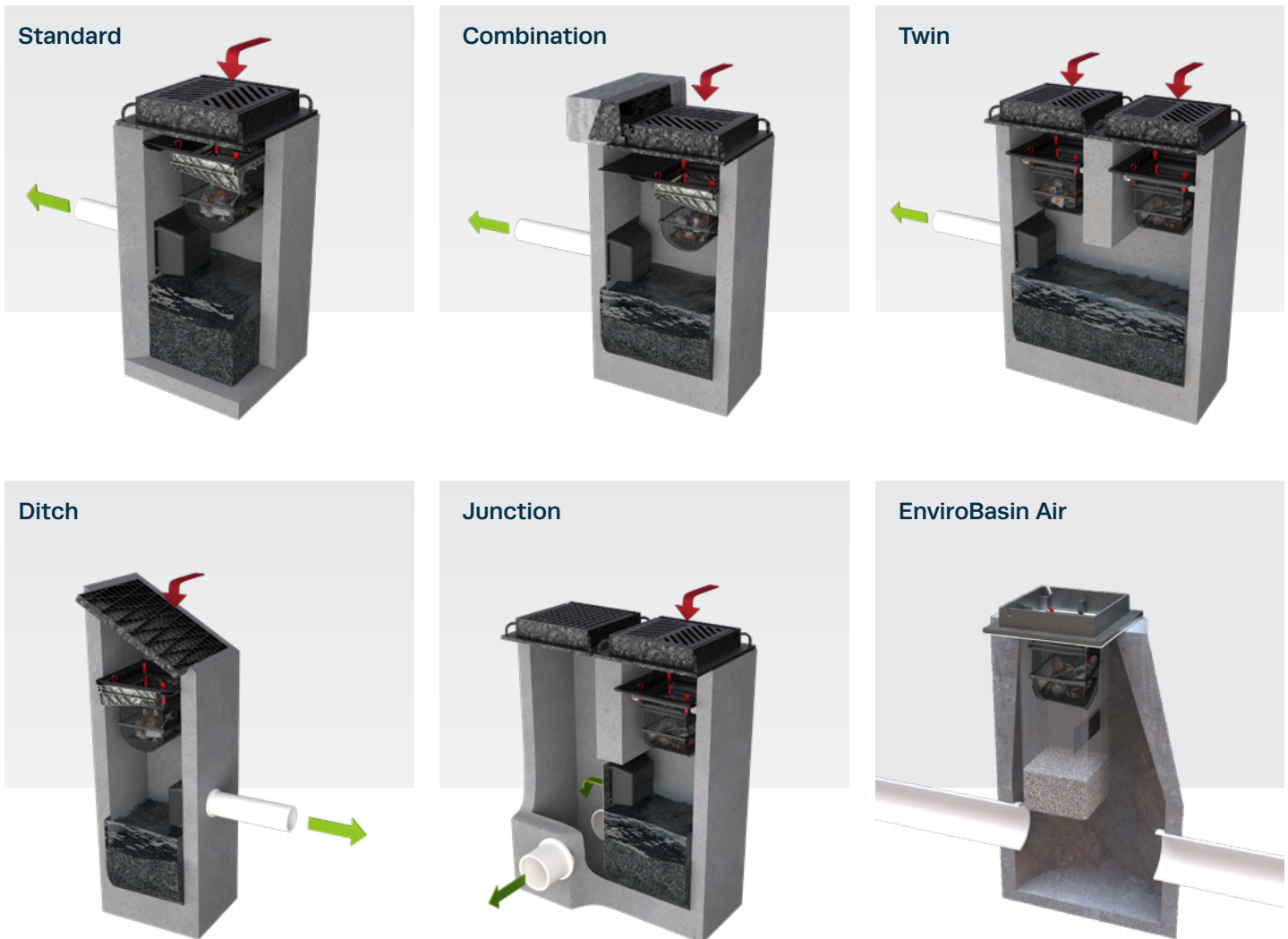

Applications

PRE-TREATMENT

Ideal pre-treatment to infiltration. As a pre-treatment device or as a stand-alone alternative to a catch basin, the EnviroBasin™ can be used in car park roads, retail, industrial sites and other high contaminant generating areas.

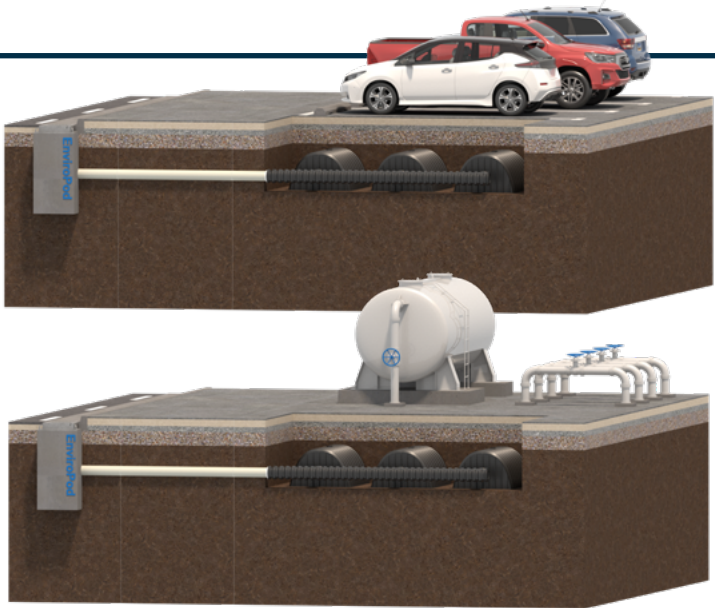

LOW IMPACT DESIGN

Ideal for pre-treatment to Low Impact Design or infiltration. Using EnviroBasin™ allows a distributed entry into these drainage structures.

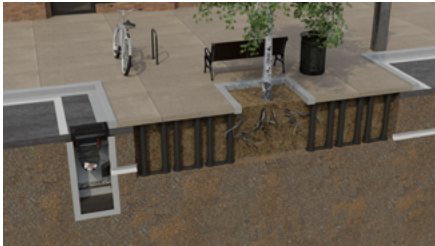

URBAN COASTAL AREAS

Ideal for urban coastal areas such as waterfronts, marinas and ports where catch basins often directly discharge into the ocean or lake.



What is ETV testing and why does it matter

In Canada and other jurisdictions, regulatory agencies and permitting authorities may have requirements and performance criteria to approve and accept various stormwater treatment devices for specific applications and operating conditions.

Regulatory agencies and authorities can benefit from scientifically defensible, verifiable performance data applicable to different end-use requirements and operating conditions.



The "Procedure for Laboratory Testing of Oil-Grit Separators" was initially prepared in 2013 by TRCA for the Canadian Environmental Technology Verification (ETV) Program and subsequent verification following the International Organization for Standardization ISO requirements 14034:2016 ETV standard, published in November 2016.

The procedure intends to provide a standard for testing and verifying the performance of OGS under controlled conditions independently and transparently. Independent verification of the performance data using the procedure as the basis for testing has assisted Canadian regulatory agencies, permitting authorities and other affected stakeholders in evaluating treatment technology options.

The ETV ISO 14034 testing standard represents a practical approach for testing to produce verifiable performance data on specific technologies under defined operating conditions. The procedure reduces uncertainties and improves the likelihood of market acceptance of the independently generated performance data, contributing to more informed technology decisions.

The EnviroBasin™ has been tested to the Procedure for Laboratory Testing of Oil-Grit Separators and has ETV-verified results.

Stormwater designers and municipalities can adopt the use of the EnviroBasin™ with confidence knowing it is verified and accepted across Canada.



Maintenance

The system is easy to maintain and the EnviroBasin's™ unique enhanced storage sump capacity extends vactor truck maintenance requirements to once every two-to-three years.

3-12
months

Routine maintenance of LittaTrap™ by hand or vactor truck (dependent on site specific loading).

2-3
years

Periodic maintenance by vactor truck maintenance of the EnviroBasin™ sump (dependent on site specific loading).



LittaTrap™ Basket Hand Maintenance

It is recommended the LittaTrap™ basket be emptied when 75% full (generally every 3-12 months). To empty the basket, simply "Lift, Tip, Reuse". The following steps detail hand maintenance:

1. Establish a safe working area per typical catch basin service activity.
2. Remove grate/access cover.
3. Remove the basket with two lifting hooks or lift by hand through the loops on the top of the basket. Excess debris should be scooped out first if the basket is over half full.
4. Pour contents of the basket into a disposal container.
5. Replace grate.



EnviroBasin™ Sump Vactor Maintenance

Steps for vactor maintenance are as detailed below:

1. Establish a safe working area per typical catch pit service activity.
2. Remove grate/access cover.
3. Vacuum accumulated debris from the basket.
4. Vactor the contents from the sump of the catch basin (if required).
5. Inspect the LittaTrap™ and EnviroBasin™ for any damage. Reinstall the LittaTrap™ basket.
6. Replace grate/access cover.



Free Design support & regulatory assistance

EnviroPod™ offers a free design service where the cumulative performance of several EnviroBasin's™ can be modeled for a specific project based on local rainfall and treatment needs. Using local rainfall data and treatment requirements, this service helps stormwater consultants optimize the placement, quantity, and sizing of EnviroBasin's™ for maximum efficiency.

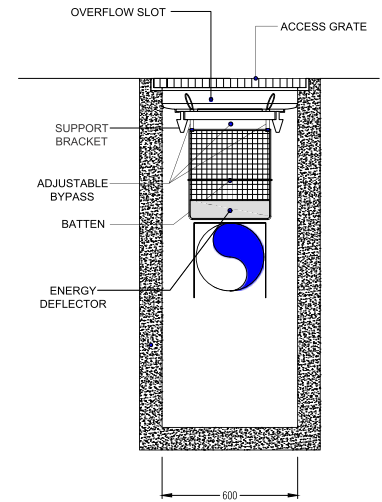

Example design calculations and drawings

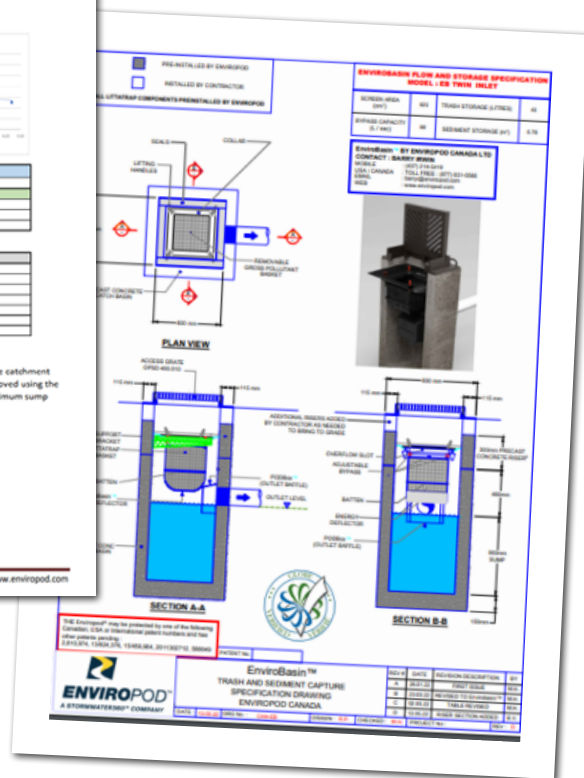

ABOUT ENVIROPOD™

EnviroPod™ is the world's leading catch basin insert technology provider. The company has over 75,000 installations worldwide, including catchment wide retrofits. The EnviroBasin™ is a result of 30 years' of research, implementation and operation of source treatment solutions.

For further information please see www.enviropod.com

International patent numbers for: CA - 2,810,974 ; USA - 9,642,658 ; AU - 2011302712 ; NZ - 588049. Other patents pending.

